



Content

1. Applications & Features
2. Abstract
3. Microscopy in Cell Biology
4. Substrates in Microscopy
5. SCREENSTAR and SensoPlate™ Plus: Microplates for High Resolution Microscopy
6. Image Quality in SensoPlate™ Plus Microplates / Optical Transparency of the SCREENSTAR Film Bottom
7. Packaging of 96 Well SCREENSTAR Microplates
8. Ordering Information

SCREENSTAR and SensoPlate™ Plus: Microplates for Advanced Microscopy

1. Applications & Features

1.1 Applications

- High content screening
- Water or oil immersion objectives
- High magnification objectives (40x and above)
- High resolution objectives

1.2 Features

- SCREENSTAR: 190 µm cycloolefin film bottom microplate
- SENSOPLATE Plus™: 175 µm glass bottom microplate
- Recessed microplate bottom for high magnification and improved resolution
- Superior bottom quality to enable high-quality images
- Meets ANSI standards
- Universal microscope objective compatibility
- Proven cell culture surface treatment

2. Abstract

SCREENSTAR and SensoPlate™ Plus are microplates for advanced microscopic applications such as high content screening with water or oil immersion objectives. The special design of the two microplates allows low working distances and combines excellent optical features with high quality surfaces for cell culture and biochemical assays.

SCREENSTAR microplates are manufactured with an optically transparent 190 µm cycloolefin film bottom.

SensoPlate™ Plus microplates are manufactured with a 175 µm borosilicate glass bottom.

3. Microscopy in Cell Biology

Microscopy is a basic and highly important method in life science frequently used in research as well as medical diagnostics such as histological cancer classification. Technological progression in confocal microscopy, optical systems and emerging technologies such as total internal reflection fluorescence microscopy (TIRFM), continues to elevate microscopy as one of the most powerful tools in cell biology.

Unless intentionally cultivated as suspension or spheroidal cultures, adherent cells and tissues customarily require a surface to attach and/or grow (Fig. 1).

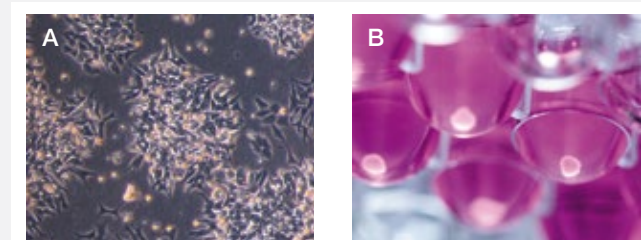

Figure 1:
A) HEK 293 cells growing on the surface of a black clear bottom (µClear®) tissue culture treated microplate (Cat. No. 655 090)
B) Tumour spheroid in a well of CELLSTAR® cell-repellent U-bottom microplate (Cat. No. 650 970)

Typical specimen supports in microscopy for cells or tissues are objective slides, flasks, dishes and microplates. For microscopic analysis, inverted microscopes are commonly used. The objective is positioned below the microscope stage that houses the substrate containing the biological specimen, causing inclusion of the biological sample support within the optical pathway (Fig. 2) of microscopic detection.

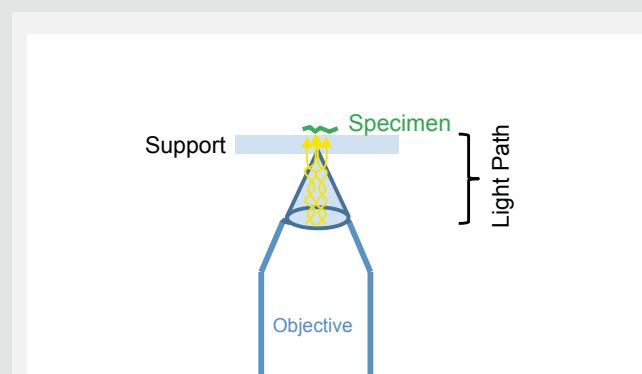

Figure 2: Specimen support, e.g. microscopic slide as part of the light path in an optical system

Coming from standard top microscopy, microscope objectives are typically calibrated to accommodate a 175 µm glass surface, as the standard thickness of cover slip glass. However, microscope slides, standard flasks, dishes and multiwell plates or microplates generally feature an approximate 1 mm bottom thickness (Fig. 3, Table 1). For demanding microscopic applications at higher magnifications, a 1 mm bottom thickness can lead to a major reduction in resolution due to focusing problems with standard specimen supports. This effect is exacerbated especially with oil or water immersion objectives, as the microscope objectives are typically calibrated to the refractive index of glass, which differs from air or oil (Table 2), as well as adjusted to a cover slip glass thickness of 175 µm.

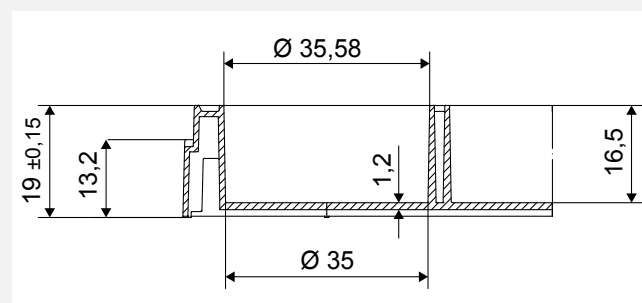

Figure 3: Well of a clear 6 well tissue culture treated microplate (Cat. No. 657 160), a frequently used format in cell biology. Well bottom thickness: 1.2 mm

Table 1: Well bottom thickness

Cat. No.	Description	Well Bottom Thickness	Distance Well Bottom Internal	Distance Well Bottom External
664 160	Cell Culture Dish	1 mm	1.6 mm	0.6 mm
658 175	Cell Culture Flask	1.4 mm	2.5 mm	1.1 mm
657 160	6 Well Multiwell Plate	1.2 mm	2.5 mm	1.3 mm
665 180	24 Well Multiwell Plate	1.2 mm	2.5 mm	1.3 mm
655 180	96 Well Solid Bottom Microplate	0.95 mm	3.5 mm	2.55 mm
655 090	96 Well μ Clear [®] Microplate	0.19 mm	3.5 mm	3.31 mm
655 866	96 Well SCREENSTAR Microplate	0.19 mm	0.7 mm	0.51 mm
655 891	96 Well SensoPlate [™] Plus Microplate	0.175 mm	0.7 mm	0.525 mm

Table 2: Refractive index of different materials

Media	Refractive Index
Air	1.0
Glycerine	1.47
Water	1.33
Immersion Oil	1.52
Glass	1.52
Cycloolefine	1.53
Polystyrene	1.58

For sophisticated microscopic applications, specialised supports that feature a 175 μ m bottom thickness can be advantageous (Fig. 4). In example, for high resolution non-invasive fluorescence microscopy of live organisms and cells, small petri dishes that contain an embedded 175 μ m glass cover slip bottom such as the CELLview[™] Dish (Fig. 5) can be used to perform multi-position time-lapse imaging.



Figure 5: CELLview[™] Dish (Cat. No. 627 8XX and 627 9XX)

Fluorescence Microscopy of HELA cells, 63x (LSM 710 Zeiss)

- cytoplasm
- nucleus
- cytoskeleton

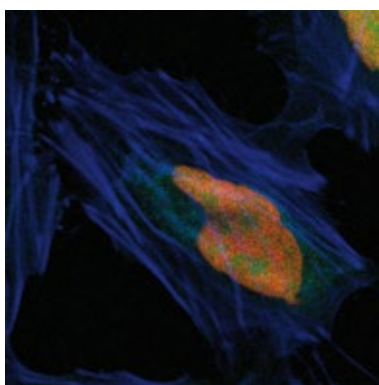

Polystyrene
(μ Clear[®] bottom)
190 μ m

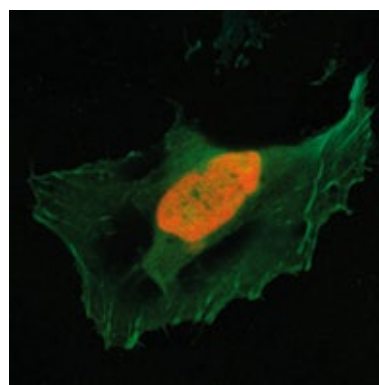

SensoPlate[™] Plus
(glass bottom)
175 μ m

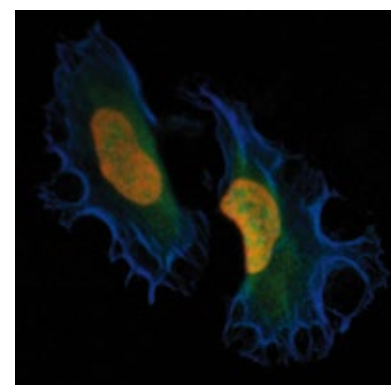

SCREENSTAR
(cycloolefin bottom)
190 μ m

Polystyrene and cycloolefin yield high resolution similar to glass

Figure 4: Fluorescence microscopy with an inverted microscope (LSM 710, Carl Zeiss AG, Germany, 63x with oil). Comparison of different base materials of ultra-thin bottoms: polystyrene (μ Clear[®] film), glass (SensoPlate[™] Plus) and cycloolefin (SCREENSTAR). All materials gave a very high resolution.

4. Substrates in Microscopy

4.1 Glass

The typical substrate for biological samples in microscopy is glass. Glass displays excellent optical properties (Fig. 4, 6, 7, 8) as it is highly transparent, clean, and less susceptible to scratching and dust contamination. Glass bottom microplates such as the new 96 well SensiPlate™ Plus feature excellent intra- and inter-well flatness due to the rigidity of the glass bottom. As microscope objectives are adapted to the bottom thickness and refractive index of cover glass, generally the best optical quality with highest resolution can be achieved using glass substrates (Fig. 8).

4.2 Polystyrene

Polystyrene is the most widely used base material for microplates, and clear bottom microplates are the most appropriate for routine high throughput and high content screening applications involving microscopy and/or detections through well bottoms. In general, polystyrene microplates are reasonably priced due to highly automated production processes and relatively low material costs. The 190 μm polystyrene film bottom of the Greiner Bio-One black and white $\mu\text{Clear}^{\circledR}$ microplates is perfectly suited for microscopic applications, as it fits into the tolerance window of most microscopic objectives (Fig. 9) and does not require any special adaptations or corrective lenses. Outstanding images can be achieved

Out-of-Focus Blur of Different Materials

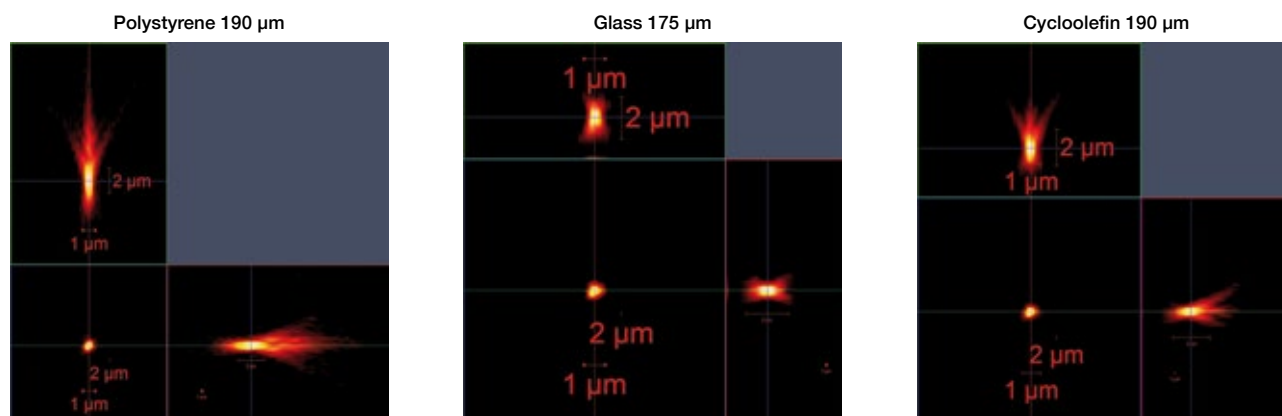

Figure 6: Confocal imaging (LSM 710, 63x, oil immersion, Carl Zeiss AG, Germany) of fluorescent beads in microplates with different bottom substrates. Images display the out-of-focus blur obtained with different materials (polystyrene, glass and cycloolefin). Cycloolefin shows approximately the same low level of out-of-focus blur as glass.

Autofluorescence of Different Materials

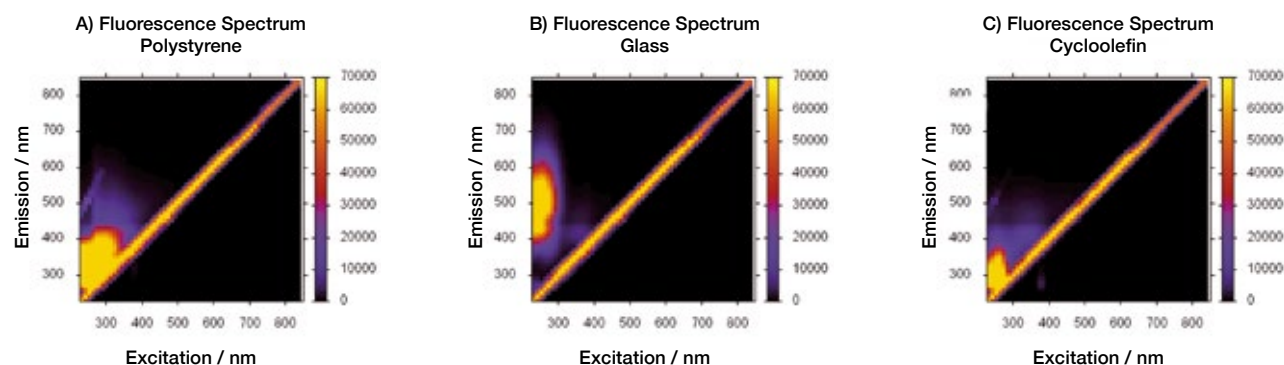
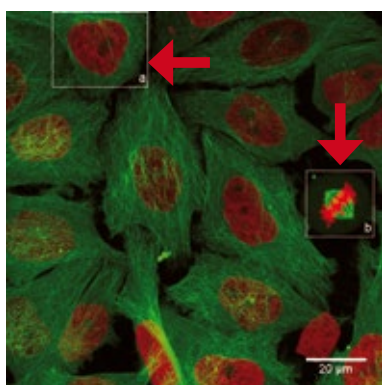

Figure 7: Autofluorescence of polystyrene (A), borosilicate glass (B) and cycloolefin (C) in the UV. The graphs display autofluorescence in a 2D diagonal plot, where the diagonal peak represents equal excitation and emission wavelengths. Due to energetic loss, emitted light generally exhibits a higher wavelength than that of excitation, therefore autofluorescence only occurs when the emission wavelength is above the excitation. The lowest autofluorescence can be detected in the cycloolefin microplates (C), followed by the glass bottom microplate (B).

due to the excellent optical quality of the polystyrene film bottom (Fig. 4). Furthermore, polystyrene can readily be modified in a surface treatment process. CELLSTAR® surfaces for adherent cells are tissue culture treated to provide a perfect support for adherence and growth of many cultures. Moreover, polystyrene can easily undergo different modifications to generate specialised surfaces for sensitive or stressed cultures such as the Greiner

Bio-One Advanced TC™ surface or CELLCOAT® protein coatings (Poly-D-Lysine, Collagen I, etc.), as well as modifications to inhibit cell attachment for suspension or spheroidal cell cultures such as with the Greiner Bio-One CELLSTAR® cell-repellent surface. The result of this flexibility is a large range of specialised surfaces within the polystyrene microplate product range for numerous and varied applications.



Control: Cell division with correct chromosome alignment (a, b)

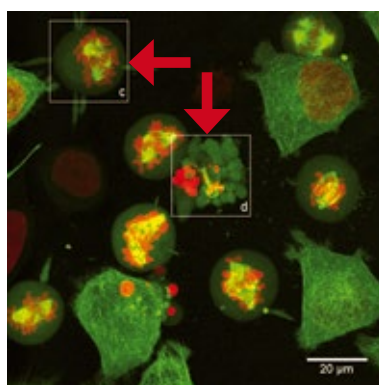

siRNA-1: Cell division with chromosome alignment problems (c) multipolar spindle (d) cell death

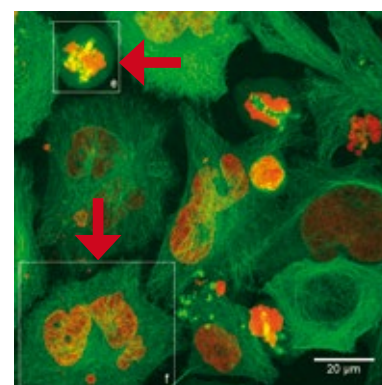

siRNA-2: Cell division with (e) chromosome segregation problem (f) polylobed nucleus

Figure 8: Phenotypic profiling of human genes by time-lapse microscopy in glass bottom microplates (96 well SensoPlate™ Plus; Cat. No. 655 891). Maximum projection of confocal still images of HeLa cells stably expressing GFP-tubulin (green) and H2B-mCherry (red) after RNAi knockdown show phenotypes during cell division and mitotic consequences such as multipolar spindle, polylobed nucleus and cell death. Images are courtesy of Dr. Beate Neumann, Advanced Light Microscopy Facility, European Molecular Biology Laboratory, Heidelberg, Germany.

Influence of Bottom Thickness on Resolution and Image Quality

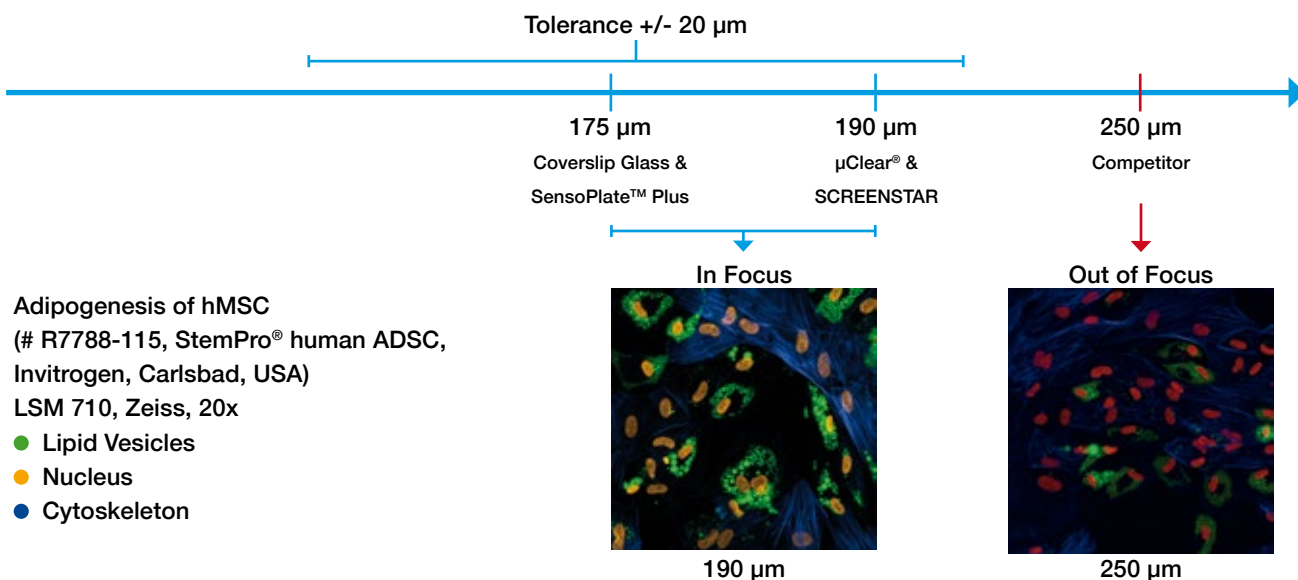

Figure 9: Influence of bottom thickness on resolution and image quality. The adipogenesis of human mesenchymal stem cells (hMSC) was analysed in microplates with 190 μm film bottom and competitive microplates with 250 μm film bottom. The 190 μm film bottom demonstrates exceptional performance, giving high image quality with excellent resolution due to the bottom thickness being within the tolerance range of the microscopic system. The 250 μm film bottom of the competitive microplate yield blurry images, incapable of sharp focus and magnifications above 20x.

4.3 Cycloolefins

Although polystyrene substrates are well suited for many cell based assay and imaging applications, with more challenging microscopic analyses, polystyrene cannot achieve the image quality of glass. Glass substrates can also show limitations for use in demanding cell culture applications, e.g. with cultivation of primary cells on glass, there is an imminent risk for cells to be washed away during the harsh immunochemical staining procedures typically required in fluorescence microscopy. Additionally, the surface modification required to improve cell attachment to glass is time-consuming and expensive.

To overcome the drawbacks for use of both glass and polystyrene as cell culture substrates, cycloolefins have become increasingly popular as a base material for microplate manufactures.

Cycloolefins comprise a new class of polymeric materials with inherent physical properties of high glass transition temperature, optical clarity, low shrinkage, low moisture absorption, and low birefringence. Cycloolefins possess excellent optical features and display a low background in the lower UV, with a refractive index and focus background comparable to glass (Table 2). Cycloolefins are frequently used to manufacture compound storage microplates due to their low water absorption, high vapour barrier, low level of leachables and resistance to DMSO, the most prevalent compound solvent in high throughput screening.

5. SCREENSTAR and SensoPlate™ Plus: Microplates for High Resolution Microscopy

The increasing significance of microscopic methods in drug discovery, with a trend of focusing on subcellular levels with higher resolution, leads to a demand for advanced microscopic technologies. Improved microscopic devices and sophisticated software programs for data analysis in the subcellular level has been launched in the recent decade. However, the exploitation of the technical benefits in high content screening has been somewhat limited due to restrictions in the design and performance of the available specimen supports.

The abundantly available microscope slide is not suitable for high content screening applications where multiple samples must be analysed in parallel. Rather, microplates have become the standard substrate of choice in high content screening, as they facilitate an easy automation and analysis.

Recessed Microplate Bottom of SCREENSTAR and SensoPlate™ Plus Microplates



Figure 10: 40x water immersion objective for microscopic detection in a 96 well microplate.

Within the standard 96 well microplate design, the distance between well undersides and microplate skirt bottom causes interference of oil or water immersion objectives with the microplate skirt.

This is not the case with the SCREENSTAR or the SensoPlate™ Plus microplates, as the recessed well bottoms enable a close proximity for the objectives to fully access all microplate wells.

Recessed Microplate Bottom

One of the major drawbacks of a classic polystyrene microplate is the distance from the microplate well undersides to the plate skirt bottom. In microscopy, a distance of greater than 1 mm can prohibit access to peripheral wells, especially when high magnification objectives that almost touch the well undersides, separated just by a thin oil or water layer, are used. For such demanding applications, it is critical that the microplate well undersides are in very close proximity to the bottom of the microplate skirt to allow full access of the objective to all peripheral microplate wells.

The new SensoPlate™ Plus and SCREENSTAR microplates provide a recessed, optically transparent bottom to allow full use of high magnification oil or water immersion objectives with access to all microplate wells, including perimeter and corner positions (Fig. 10).

5.1 1536 Well SCREENSTAR Microplate

As classic polystyrene microplates are not always preferred for advanced microscopic applications, Greiner Bio-One has developed a new class of cycloolefin based microplates especially designed for microscopy. The initial microplate launched within this portfolio was the 1536 well SCREENSTAR, a black 190 µm film bottom microplate for high throughput and high content screening applications (Fig. 11). This plate is now followed by two microplates in 384 well and 96 well format.

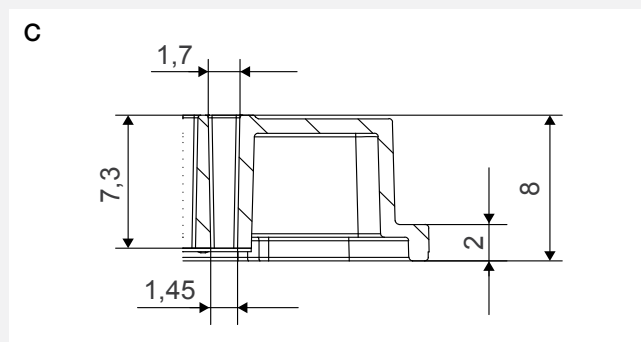
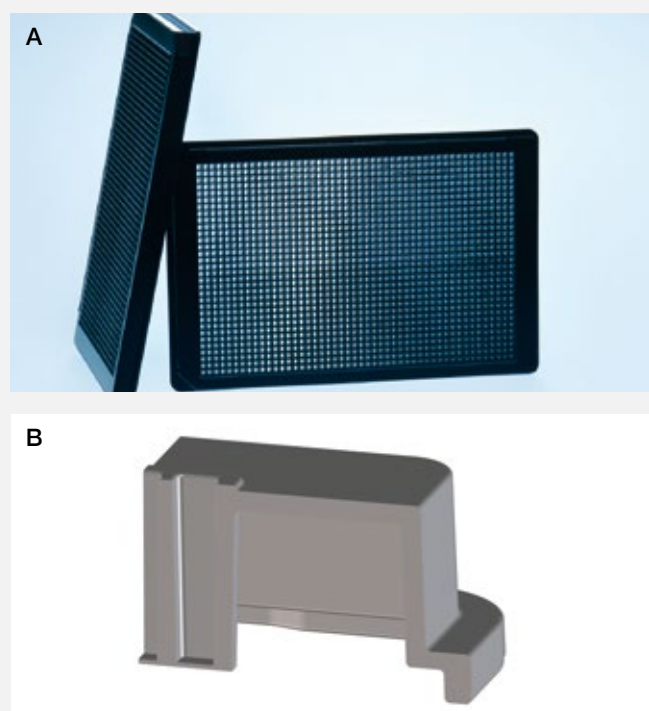

Figure 11: 1536 well SCREENSTAR Microplate

A) Black microplate with clear cycloolefin film bottom (190 µm) for high content screening

Smooth microplate top absent of alphanumeric coding facilitates flush lid mounting for use within automated systems and improves heat sealing

B + C) Well design of a 1536 well SCREENSTAR microplate

Plate height:	8 mm
Well depth:	7.3 mm
Well diameter top:	1.7 mm
Well diameter bottom:	1.45 mm
Distance microplate rim to internal well bottom:	0.7 mm
Distance microplate rim to external well bottom:	0.51 mm
Film bottom thickness:	190 µm

5.2 384 Well SCREENSTAR and SensoPlate™ Plus Microplate

SensoPlate™ Plus with 175 µm glass bottom and the new 384 well SCREENSTAR microplate with 190 µm film bottom are microplates with recessed well bottoms for advanced microscopic applications.

In contrast to the 96 well SCREENSTAR and 96 well SensoPlate™ Plus microplates where the basic design of the plate is identical, the 384 well SensoPlate™ Plus features differences in well geometry and plate design from the 384 well SCREENSTAR microplate (Fig. 12 and 13).

The major difference is the distance of the film or glass bottom from the microplate skirt. The 384 well SCREENSTAR displays external and internal well bottom to skirt distances of 1.11 mm and 1.3 mm, respectively, whereas SensoPlate™ Plus features the classical distances of 0.525 mm / 0.7 mm.

Additionally, the 384 well SCREENSTAR microplate has a smooth microplate top absent of alphanumeric coding which facilitates flush lid mounting for use within automated systems and improves heat sealing.

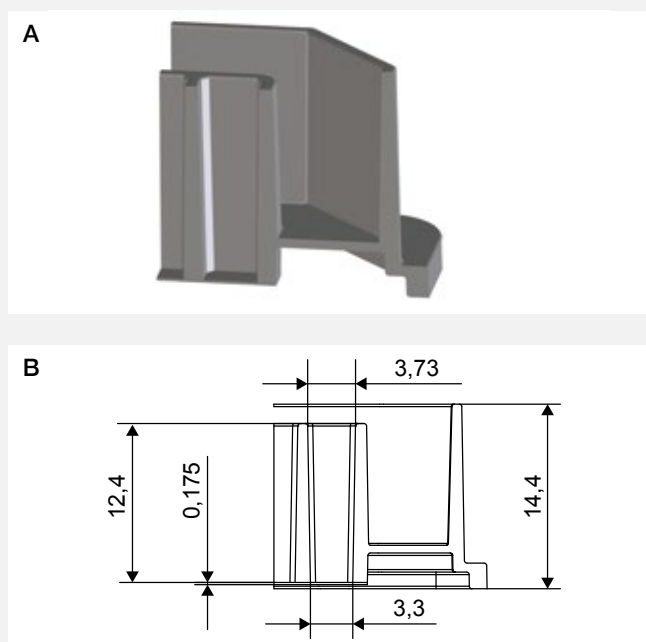

Figure 12: 384 well SensoPlate™ Plus Microplate

A+B) Microplate design and well geometry of 384 well SensoPlate™ Plus: Black microplate with clear glass bottom for high resolution microscopy

Plate height:	14.4 mm
Well depth:	12.4 mm
Well diameter top:	3.73 mm
Well diameter bottom:	3.3 mm
Distance microplate rim to internal well bottom:	0.7 mm
Distance microplate rim to external well bottom:	0.525 mm
Glass bottom thickness:	175 µm

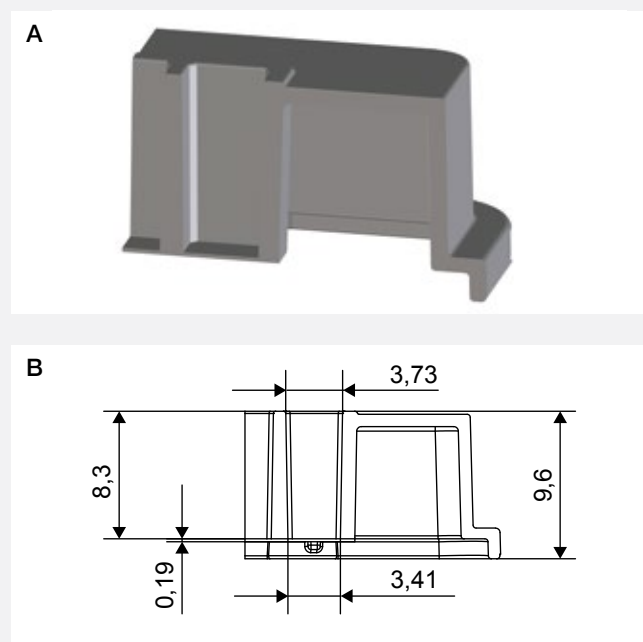

Figure 13: 384 well SCREENSTAR Microplate

A+B) Microplate design and well geometry of 384 well SCREENSTAR: Black clear film bottom microplate for high content screening

Plate height:	9.6 mm
Well depth:	8.3 mm
Well diameter top:	3.73 mm
Well diameter bottom:	3.41 mm
Distance microplate rim to internal well bottom:	1.3 mm
Distance microplate rim to external well bottom:	1.11 mm
Film bottom thickness:	190 µm

5.3 96 well SCREENSTAR and 96 well SensoPlate™ Plus Microplate

5.3.1 Plate Dimensions and Tolerances

The 96 well SCREENSTAR and SensoPlate™ Plus microplates (Fig. 14) meet the ANSI 1-2004 through ANSI 4-2004 standards, which define footprint, height dimensions, outer flange, and well position dimensions. The intra-well and inter-well flatness are described by the ANSI 6-2012: „Microplates - Well Bottom Elevation“. Most optical devices can deal with an overall flatness (inter-well flatness) below 0.2 mm, which is specified for the new SCREENSTAR and SensoPlate™ Plus microplates.

5.3.2 Improved Cell Culture Conditions (enlarged working volume and perimeter ditch)

Demanding cell biology applications, such as detection of subcellular reactions, require prolonged cell culture, to include critical media changes. Low working volumes and high evaporation during such long term cell culture could adversely affect the consistency and performance of a cell-based assay.

To reduce evaporation, the 96 well SCREENSTAR and SensoPlate™ Plus microplates offer a ditch around the perimeter which can be filled with either sterile media or water (Fig. 15). This can help create a saturated water vapour barrier to significantly reduce evaporation.

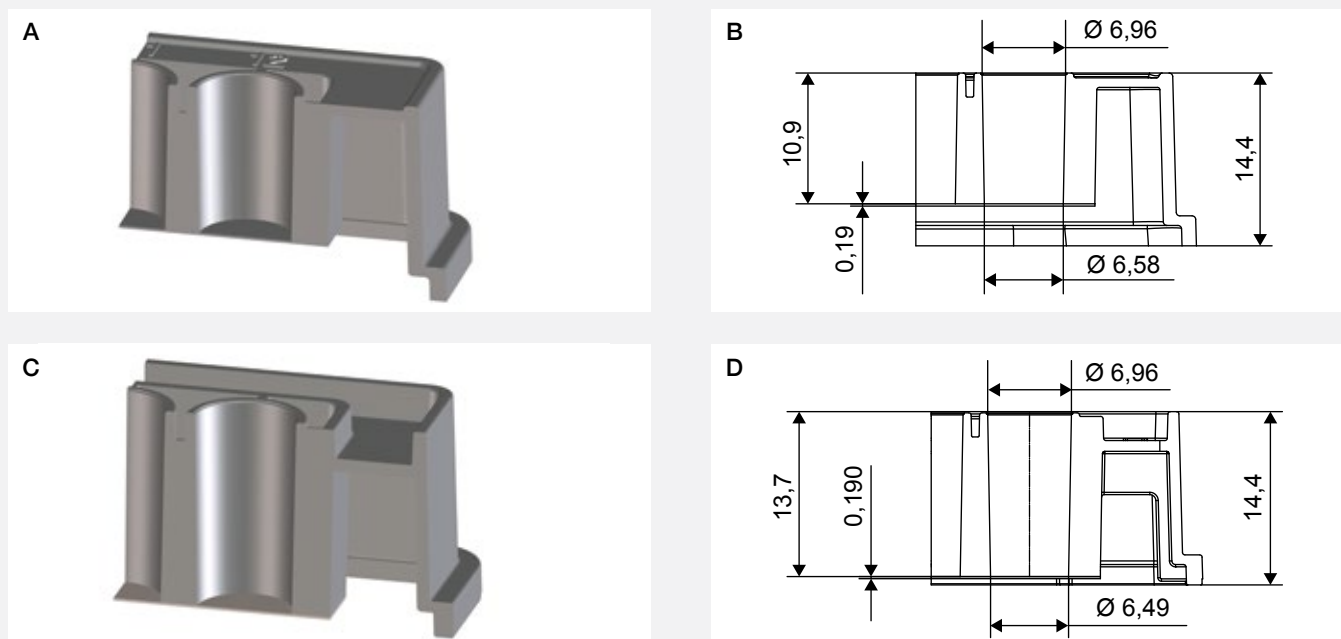

Figure 14:

A) Well bottom distance in a 96 well microplate (Cat. No. 655 090)

C) Well bottom distance in a 96 well SCREENSTAR microplate (Cat. No. 655 866 and 655 891)

A basic requirement for the 96 well SCREENSTAR and SensoPlate™ Plus microplate was the compatibility of high magnification objectives such as oil and water immersion lenses. These objectives almost touch the microplate well undersides, separated just by a thin oil or water layer. For this technology, the microplate well undersides must be close to the microplate skirt bottom (Fig. 10) to easily allow interchange of microscopic objectives and complete access of peripheral wells.

B) Well design of a 96 well μClear® PS microplate (Cat. No. 655 090)

Plate height:	14.4 mm
Well depth:	10.9 mm
Well diameter top:	6.96 mm
Well diameter bottom:	6.58 mm
Distance microplate rim to internal well bottom:	3.5 mm
Distance microplate rim to external well bottom:	3.31 mm
Film bottom thickness:	190 μm

D) Well design of a 96 well SCREENSTAR microplate (Cat. No. 655 866)

Plate height:	14.4 mm
Well depth:	13.7 mm
Well diameter top:	6.96 mm
Well diameter bottom:	6.49 mm
Distance microplate rim to internal well bottom:	0.7 mm
Distance microplate rim to external well bottom:	0.51 mm
Film bottom thickness:	190 μm

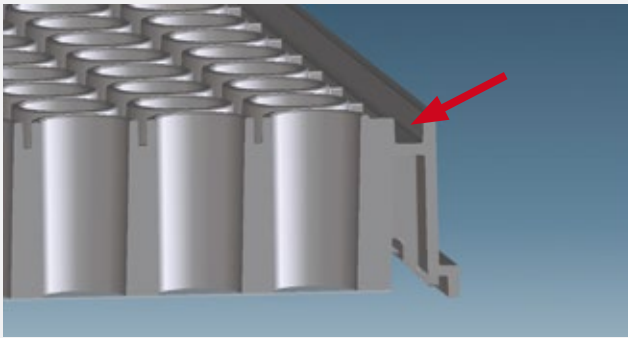

Figure 15: Detail of the new 96 well SCREENSTAR microplate demonstrating the perimeter ditch which can be filled with sterile water or media
 Well depth: 13.7 mm Working volume: 25 - 440 µl
 Growth area: 33 mm² Total volume: 483 µl
 Well diameter (bottom): 6.49 mm

Table 3: Comparison of the major microplate and well dimensions between SCREENSTAR / SensoPlate™ Plus and a standard 96 well chimney well microplate

Description	SCREENSTAR SensoPlate™ Plus	Standard Chimney Well
Length / Width	127.76 x 85.48 mm	127.76 x 85.48 mm
Height	14.4 mm	14.4 mm
A1 position	11.01 x 7.87 mm	11.01 x 7.87 mm
Top	6.96 mm	6.96 mm
Bottom	6.49 mm	6.58 mm
Skirt	2.0 mm	2.0 mm
Pitch	9 mm	9 mm
Well depth	13.7 mm	10.9 mm
Total volume	483 µl	392 µl
Working volume	25 - 440 µl	25 - 340 µl
Growth area	33 mm ²	34 mm ²

With a working volume of 440 µl/well in SCREENSTAR and SensoPlate™ Plus, the volume is increased nearly 100 µl in comparison to a standard 96 well chimney well design (Table 3).

The larger working volume enables use of more media to potentially enlarge time periods between media changes. The nutrition of cells can additionally be improved due to the application of a higher volume of media.

Fluorescence Microscopy of HELA Cells cultivated on Different Microplate Surfaces

40 x Leica DM IL Fluo (Leica Microsystems GmbH, 35578 Wetzlar, Germany)

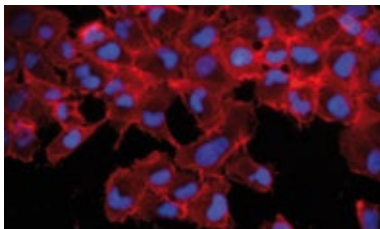

µClear® PS 190 µm

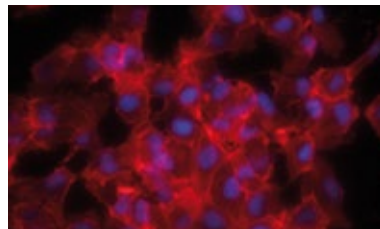

Competitor PS 250 µm

■ Phalloidin ■ DAPI

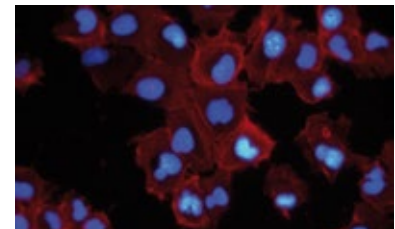

SCREENSTAR 190 µm Cycloolefin
 • excellent resolution
 • best image quality

63 x Oil Immersions (Leica Microsystems GmbH, 35578 Wetzlar, Germany)

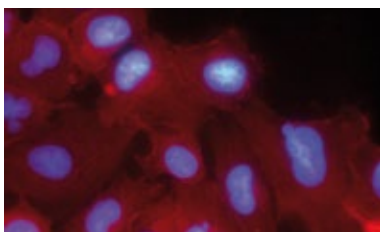

µClear® PS 190 µm

■ Phalloidin ■ DAPI

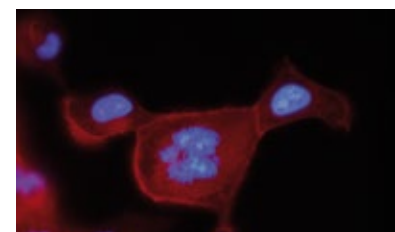

SCREENSTAR 190 µm Cycloolefin
 • excellent resolution
 • best image quality

Figure 16: Optical quality of different clear bottom microplates. SCREENSTAR microplates show excellent image quality with highest resolution.

6 Image Quality in SensoPlate™ Plus Microplates / Optical Transparency of the SCREENSTAR Film Bottom

As described in Section 4, the sum of the optical features of cycloolefin and glass help achieve an excellent image quality, especially in fluorescence microscopy if a non-confocal microscopic system or an imaging software with no point spread function for deduction of background is used. The SensoPlate™ Plus and SCREENSTAR microplates are characterised by lower autofluorescence background and capability to provide higher resolution images (Fig. 7 and 16).

In classic phase contrast light microscopy applications, impurities of the cell substrate support can detract image quality and analysis. SCREENSTAR and SensoPlate™ Plus microplate well bottoms are advantageous because of their low level of scratches, inclusions and contaminants. The bottom of a 96 well SCREENSTAR

microplate is covered by a protective film, to be removed directly before microscopic use, to protect the sensitive optical film bottom by avoiding contamination with dust or scratches.

The optical features of cycloolefin, high quality of the film that comprises the microplate well bottoms, and the clean room manufacturing conditions enable SCREENSTAR microplates to achieve an excellent image quality similar to glass, the gold standard in microscopy. The SCREENSTAR microplate additionally combines the capability for improved cell growth and cell attachment, due to the organo-polymeric nature of the cycloolefin manufacture (Fig. 17).

Cell Growth (HELA) on Different Surfaces

Crystal Violet Staining

10x Leica DM IL Fluo (Leica Microsystems GmbH, 35578 Wetzlar, Germany)

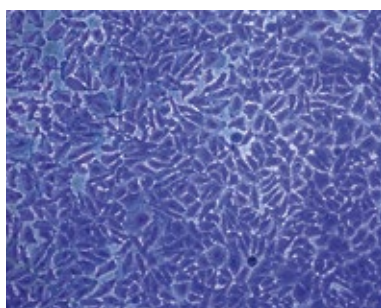

Polystyrene

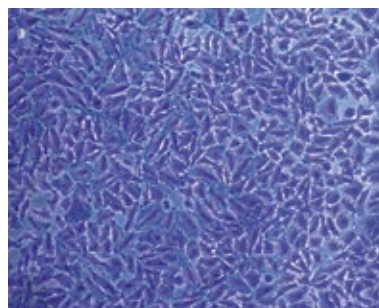

Cycloolefin

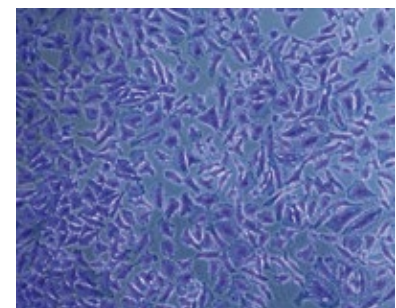

Glass

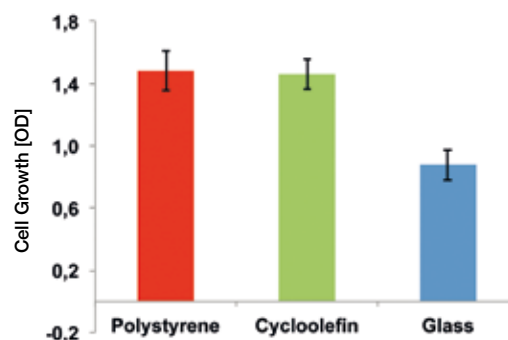

Figure 17: Cell growth in 96 well SCREENSTAR microplates compared to cell growth in 96 well polystyrene microplates

7. Packaging of 96 Well SCREENSTAR Microplates

96 well SCREENSTAR microplates are sterile with a lid, cell culture treated, individually wrapped, packaged 16 pieces per case (Fig. 18). The sensitive optical bottom of the 96 well SCREENSTAR microplate is covered with a thin protective film which must be removed prior to microscopic detection (Fig. 19).



Figure 18: Easy-to-open packaging of 96 well SCREENSTAR microplates

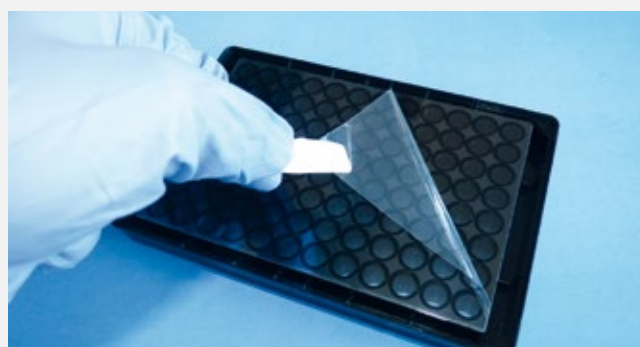

Figure 19: Protective film of 96 well SCREENSTAR microplates

8. Ordering Information

Cat.-No.	Description	Quantity per bag	Quantity per case
SCREENSTAR Microplates			
655 866	96 well SCREENSTAR microplate, cycloolefin, black, 190 µm film bottom, cell culture treated, sterile, with lid	1	16
789 836	384 well, SCREENSTAR microplate, cycloolefin, black, 190 µm film bottom, cell culture treated, sterile, with ultra low profile lid	10	40
789 866	1536 well SCREENSTAR microplate, cycloolefin, black, 190 µm film bottom, cell culture treated, sterile, without lid	17	68
SensoPlate™ Plus Microplates			
655 891	96 well SensoPlate™ Plus microplate, black, 175 µm borosilicate glass bottom, cell culture treated, sterile, with lid	1	16
781 856	384 well SensoPlate™ Plus microplate, black, borosilicate glass bottom, extra LoBase, without lid	1	16
783 856	1536 well SensoPlate™ Plus microplate, black, borosilicate glass bottom, extra LoBase, without lid	4	16

www.gbo.com/bioscience

Germany (Main office): Greiner Bio-One GmbH, info@de.gbo.com | **Austria:** Greiner Bio-One GmbH, office@at.gbo.com
Belgium: Greiner Bio-One BVBA/SPRL, info@be.gbo.com | **Brazil:** Greiner Bio-One Brasil, office@br.gbo.com
China: Greiner Bio-One Suns Co. Ltd., office@cn.gbo.com | **France:** Greiner Bio-One SAS, info@fr.gbo.com
Japan: Greiner Bio-One Co. Ltd., info@jp.gbo.com | **Netherlands:** Greiner Bio-One B.V., info@nl.gbo.com
UK: Greiner Bio-One Ltd., info@uk.gbo.com | **USA:** Greiner Bio-One North America Inc., info@us.gbo.com



greiner bio-one